

Ball Bearing Units with Ductile Cast Iron Housing



2. Applications

Ductile cast iron housings are designed to be lighter and more compact than gray cast iron units. Since ductile cast iron is stronger, these compact units can commonly replace standard units. Like standard units, ductile cast iron units will perform well in harsh environments. As with all housed units, before applying, please check the allowable load limit, insert bearing life, and safety factors.

3. Housing Material

The housing material for the current standard bearing units is gray cast iron (FC200). The FC200 material contains black lead and graphite distributed as shown in **photo 1**. When heavy shock loads are applied to the housing, cracks spread along the black lead/graphite strands and the housing may fracture. In FCD450 material, the black lead and graphite nodules are distributed as shown **photo 2**. This black lead/graphite distribution can prevent the spreading of cracks. Also the shock resistance at low temperature, of FCD450 is superior to that of FC200.

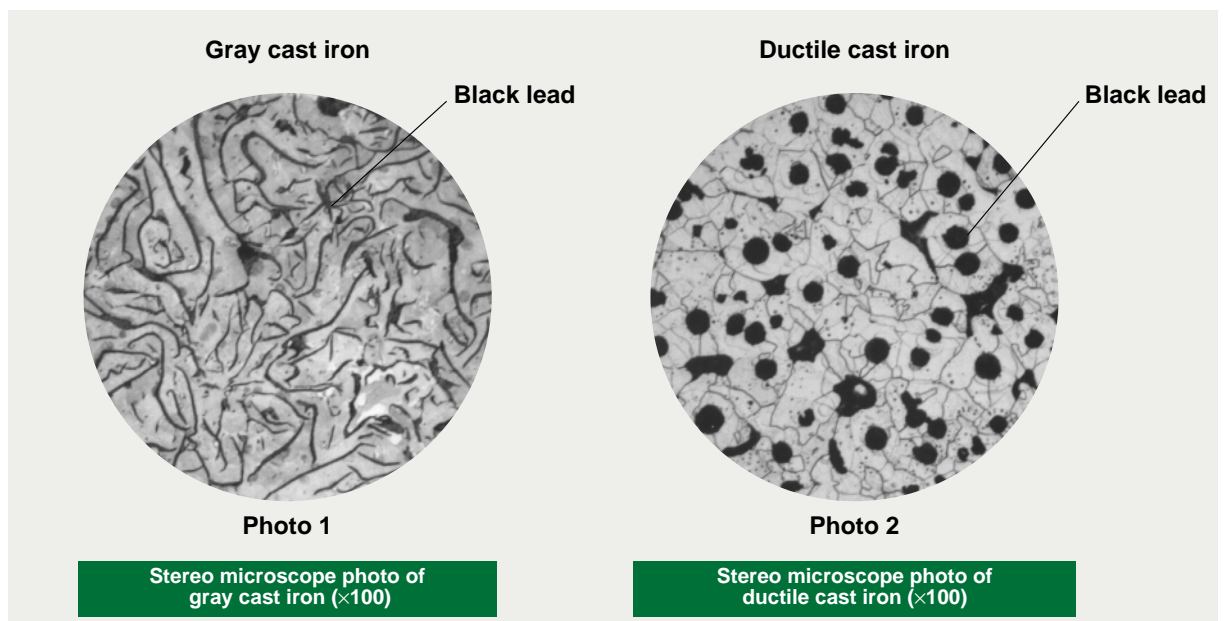
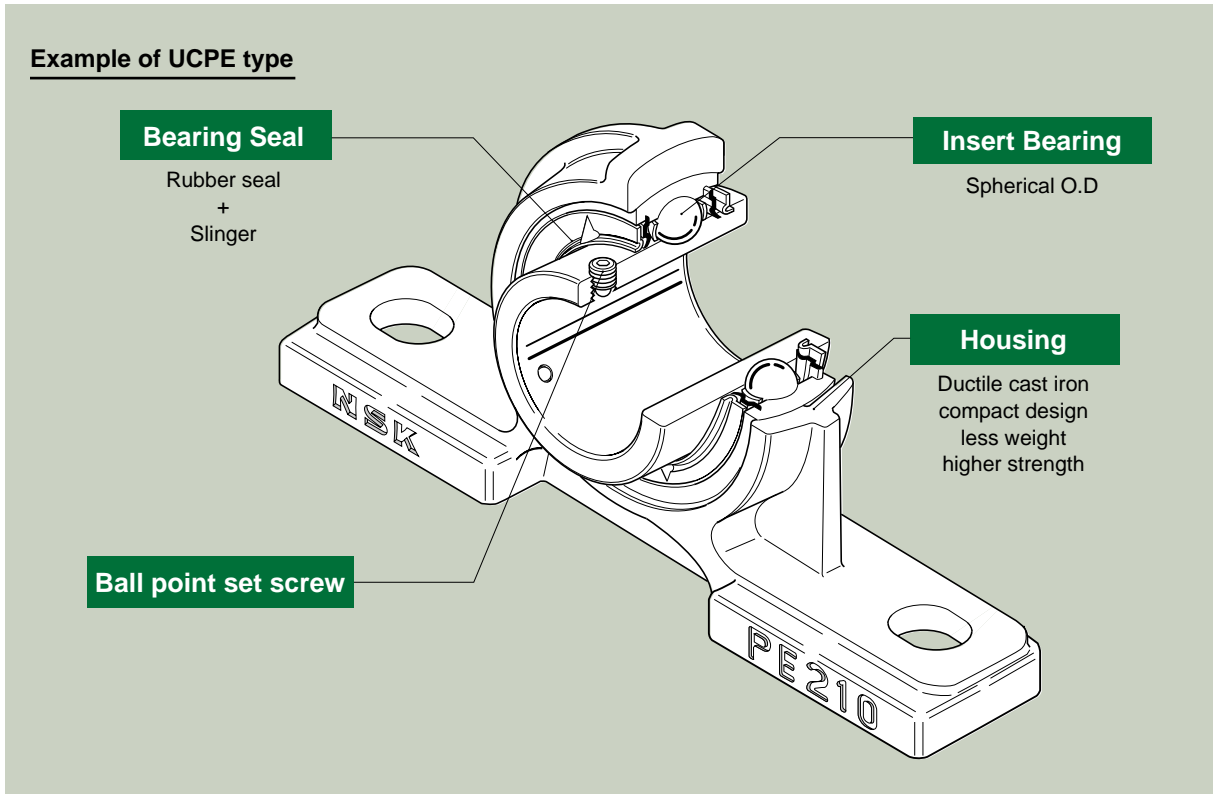

Table 1 Comparison of characteristics of ductile cast iron and gray cast iron

Material	Symbol	Tensile strength N/mm ²	Elongation %	Hardness HB
Ductile cast iron	FCD450	Minimum 450	Minimum 10	143~217
Gray cast iron	FC200	Minimum 200	Not specified	Maximum 223

30 mm non-machined test piece.

4. Design



5. Technical data

The strength of the housings are affected by unit type, direction of load, flatness, and strength of the frame on which the housings are mounted. For example, pillow block units are best suited to accept loads that are directed into the the base of the unit. Pillow blocks are also designed to accept loads acting in other directions. When this occurs, a bearing unit with a safety factor (S_0) suitable for the application should be selected. The allowable housing load can be calculated with equation (1). A guide for suitable safety factors is shown in **Table 2**.

$$P_0 = P_{st} / S_0 \text{----- (1)}$$

P_0 : allowable housing load (N)
 P_{st} : static strength of housing (N)
 S_0 : safety factor (**Table 2**)

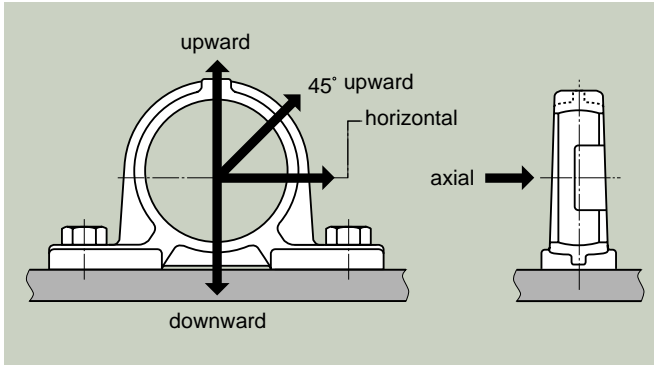

Table 2 Safety factor of housing.

Load		Safety factor S_0
Static Load		4
Alternative Load	One direction	6
	Bidirectional	10
Shock Load		15

- When pillow block type units are under large horizontal loads or large loads angled upwards at 45°, the housing may slip at the base. An axial stopper should be designed to prevent this.
- A safety cover should be designed to protect the operator.

Table 3 Static strength of housing for pillow block type unit.

Unit : 10^3 N

Load direction Basic size	Upward		45° Upward		Horizontal		Downward		Axial	
	PE	P	PE	P	PE	P	PE	P	PE	P
203	30	25	25	21	45	36	90	75	11	10
204	33	27	30	23	47	36	100	80	17	16
205	40	29	37	25	57	50	118	95	20	17
206	50	37	43	32	67	53	137	130	26	22
207	59	41	50	34	78	57	160	160	31	23
208	71	43	54	35	90	62	186	170	34	24
209	79	44	65	36	100	66	215	180	41	25
210	88	48	75	38	110	74	255	200	46	27
211	105	56	81	44	140	100	350	210	55	34
212	123	72	95	55	172	118	400	280	70	40

PE : Ductile housing P : NSK standard

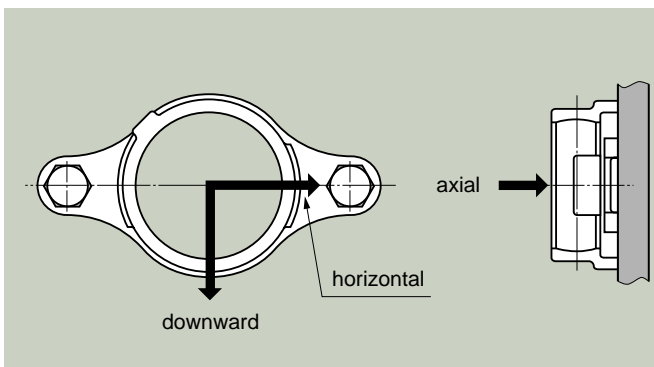

Table 4 Static strength of housing for flange type unit.

Unit : 10^3 N

Load direction Basic size	Horizontal		Downward		Axial	
	FE	FL	FE	FL	FE	FL
204	30	16	45	28	41	20
205	37	20	54	48	42	28
206	53	25	62	49	43	29
207	68	40	70	50	44	29
208	81	68	79	52	46	30
209	106	70	87	65	48	33
210	113	72	96	85	51	40
211	165	101	147	107	77	74
212	203	150	151	152	84	77

FE : Ductile housing FL : NSK standard

Pillow block unit

UCPE type

Cylindrical bore with set screw

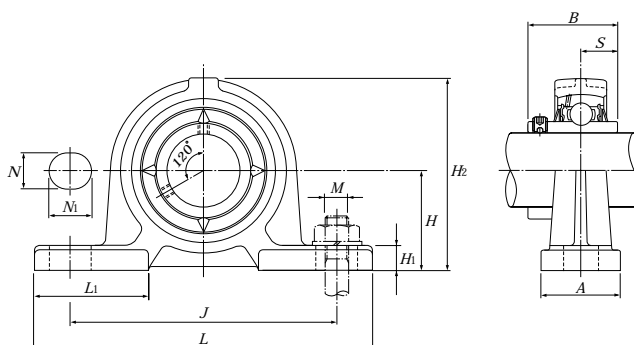

Shaft dia. mm	Unit number	Bearing number	Housing number	Nominal dimensions mm											Bolt size M	Basic load ratings		Mass of unit kg
				H	L	J	A	N	N _i	H _i	H ₂	L _i	B	S		dynamic kN C _r	static kN C _{0r}	
12	UCPE201	UC201D1	PE203	30.2	120	95	30	12	14	9	61	42	31	12.7	M10	12.8	6.65	0.5
15	UCPE202	UC202D1	PE203	30.2	120	95	30	12	14	9	61	42	31	12.7	M10	12.8	6.65	0.5
17	UCPE203	UC203D1	PE203	30.2	120	95	30	12	14	9	61	42	31	12.7	M10	12.8	6.65	0.5
20	UCPE204	UC204D1	PE204	33.3	120	95	30	12	14	9	64	42	31	12.7	M10	12.8	6.65	0.5
25	UCPE205	UC205D1	PE205	36.5	130	105	30	12	14	10	70	42	34.1	14.3	M10	14.0	7.85	0.5
30	UCPE206	UC206D1	PE206	42.9	155	121	36	17	20	11	82	54	38.1	15.9	M14	19.5	11.3	0.9
35	UCPE207	UC207D1	PE207	47.6	161	127	38	17	20	12	92	54	42.9	17.5	M14	25.7	15.3	1.1
40	UCPE208	UC208D1	PE208	49.2	171	137	40	17	20	12	98	52	49.2	19	M14	29.1	17.8	1.4
45	UCPE209	UC209D1	PE209	54	180	146	40	17	20	13	105	60	49.2	19	M14	32.5	20.4	1.5
50	UCPE210	UC210D1	PE210	57.2	195	159	45	19	22	14	114	65	51.6	19	M16	35.0	23.2	1.8
55	UCPE211	UC211D1	PE211	63.5	207	171	45	19	22	15	125	65	55.6	22.2	M16	43.5	29.2	2.7
60	UCPE212	UC212D1	PE212	69.8	220	184	55	19	22	17	137	70	65.1	25.4	M16	52.5	36.0	3.7

① If relubricatable type is needed, please order with suffix "D1". (Ex:UCPE201D1)

Flange unit

UCFE type

Cylindrical bore with set screw

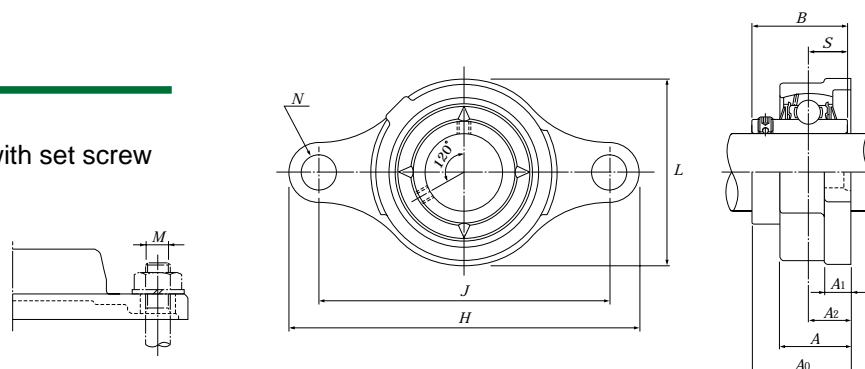

Shaft dia. mm	Unit number	Bearing number	Housing number	Nominal dimensions mm										Bolt size M	Basic load ratings		Mass of unit kg
				H	J	A ₂	A ₁	A	N	L	A ₀	B	S		dynamic kN C _r	static kN C _{0r}	
12	UCFE201	UC201D1	FE204	112	90	15	10	25	12	57	33.3	31	12.7	M10	12.8	6.65	0.4
15	UCFE202	UC202D1	FE204	112	90	15	10	25	12	57	33.3	31	12.7	M10	12.8	6.65	0.4
17	UCFE203	UC203D1	FE204	112	90	15	10	25	12	57	33.3	31	12.7	M10	12.8	6.65	0.4
20	UCFE204	UC204D1	FE204	112	90	15	10	25	12	57	33.3	31	12.7	M10	12.8	6.65	0.4
25	UCFE205	UC205D1	FE205	127	99	16	10	26	16	62	35.8	34.1	14.3	M14	14.0	7.85	0.4
30	UCFE206	UC206D1	FE206	145	117	18	10	30	16	73	40.2	38.1	15.9	M14	19.5	11.3	0.7
35	UCFE207	UC207D1	FE207	158	130	19	12	32	16	86	44.4	42.9	17.5	M14	25.7	15.3	1.0
40	UCFE208	UC208D1	FE208	172	144	21	12	35	16	95	51.2	49.2	19	M14	29.1	17.8	1.2
45	UCFE209	UC209D1	FE209	180	148	22	13	36	19	101	52.2	49.2	19	M16	32.5	20.4	1.4
50	UCFE210	UC210D1	FE210	189	157	22	13	37	19	106	54.6	51.6	19	M16	35.0	23.2	1.6
55	UCFE211	UC211D1	FE211	216	184	25	18	41	19	118	58.4	55.6	22.2	M16	43.5	29.2	2.5
60	UCFE212	UC212D1	FE212	241	202	29	18	46	23	129	68.7	65.1	25.4	M20	52.5	36.0	3.4

① If relubricatable type is needed, please order with suffix "D1". (Ex:UCFE201D1)

Note: Please check NSK catalogue NO.E1154. for tolerances of insert and housings. Tolerance of insert bearings according to JIS B 1558. Tolerance of housing according to JIS B 1559. If inch size bore is needed, please contact NSK.

Pillow block unit

UKPE type

Tapered bore with adapter

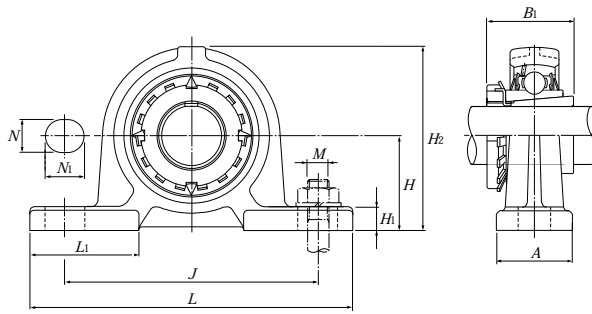

Shaft dia. mm	Unit [●] number	Bearing number	Housing [●] number	Nominal dimensions mm										Bolt size M	Basic load ratings		Mass of unit kg
				H	L	J	A	N	N ₁	H ₁	H ₂	L ₁	B ₁		dynamic kN C _r	static kN C _{0r}	
20	UKPE205;H2305X	UK205D1;H2305X	PE205	36.5	130	105	30	12	14	10	70	42	35	M10	14.0	7.85	0.6
25	UKPE206;H2306X	UK206D1;H2306X	PE206	42.9	155	121	36	17	20	11	82	54	38	M14	19.5	11.3	0.9
30	UKPE207;H2307X	UK207D1;H2307X	PE207	47.6	161	127	38	17	20	12	92	54	43	M14	25.7	15.3	1.2
35	UKPE208;H2308X	UK208D1;H2308X	PE208	49.2	171	137	40	17	20	12	98	52	46	M14	29.1	17.8	1.5
40	UKPE209;H2309X	UK209D1;H2309X	PE209	54	180	146	40	17	20	13	105	60	50	M14	32.5	20.4	1.6
45	UKPE210;H2310X	UK210D1;H2310X	PE210	57.2	195	159	45	19	22	14	114	65	55	M16	35.0	23.2	2.0
50	UKPE211;H2311X	UK211D1;H2311X	PE211	63.5	207	171	45	19	22	15	125	65	59	M16	43.5	29.2	2.9
55	UKPE212;H2312X	UK212D1;H2312X	PE212	69.8	220	184	55	19	22	17	137	70	62	M16	52.5	36.0	3.8

● If relubricatable type is needed, please order with suffix "D1". (Ex:UKPE205D1;H2305X)

Flange unit

UKFE type

Tapered bore with adapter

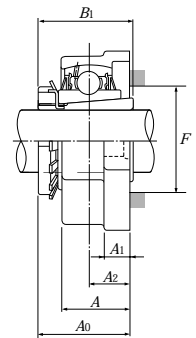
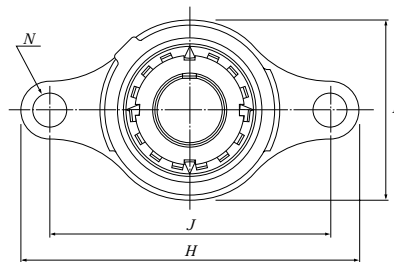
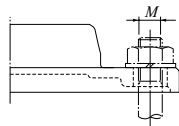

Shaft dia. mm	Unit [●] number	Bearing number	Housing [●] number	Nominal dimensions mm											Bolt size M	Basic load ratings		Mass of unit kg
				H	J	A ₂	A ₁	A	N	L	A ₀	B ₁	F _{min}	dynamic kN C _r		static kN C _{0r}		
20	UKFE205;H2305X	UK205D1;H2305X	FE205	127	99	16	10	26	16	62	35.5	35	30	M14	14.0	7.85	0.5	
25	UKFE206;H2306X	UK206D1;H2306X	FE206	145	117	18	10	30	16	73	39	38	36	M14	19.5	11.3	0.7	
30	UKFE207;H2307X	UK207D1;H2307X	FE207	158	130	19	12	32	16	86	42.5	43	40	M14	25.7	15.3	1.0	
35	UKFE208;H2308X	UK208D1;H2308X	FE208	172	144	21	12	35	16	95	46.5	46	46	M14	29.1	17.8	1.3	
40	UKFE209;H2309X	UK209D1;H2309X	FE209	180	148	22	13	36	19	101	48.5	50	52	M16	32.5	20.4	1.5	
45	UKFE210;H2310X	UK210D1;H2310X	FE210	189	157	22	13	37	19	106	50	55	57	M16	35.0	23.2	1.8	
50	UKFE211;H2311X	UK211D1;H2311X	FE211	216	184	25	18	41	19	118	54.5	59	64	M16	43.5	29.2	2.7	
55	UKFE212;H2312X	UK212D1;H2312X	FE212	241	202	29	18	46	23	129	61	62	69	M16	52.5	36.0	3.5	

● If relubricatable type is needed, please order with suffix "D1". (Ex:UKFE205D1;H2305X)

Note: Please check NSK catalogue NO.E1154. for tolerances of insert and housings. Tolerance of insert bearings according to JIS B 1558. Tolerance of housing according to JIS B 1559. If inch size bore is needed, please contact NSK.

Pillow block unit

UELPE type

cylindrical bore with eccentric locking collar

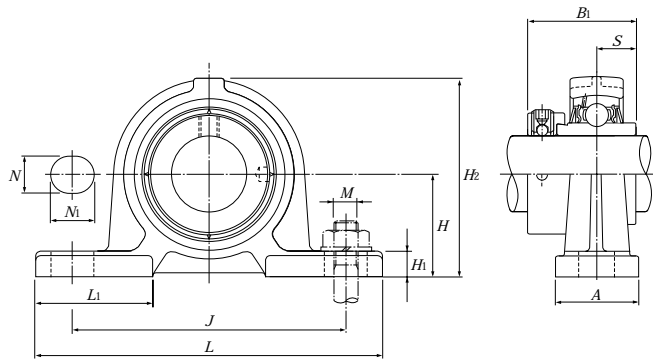

Shaft dia. mm	Unit number	Bearing number	Housing number	Nominal dimensions mm											Bolt size M	Basic load ratings		Mass of unit kg
				H	L	J	A	N	Ni	Hi	H2	Li	B1	S		dynamic kN Cr	static kN Cor	
20	UELPE204	UEL204D1	PE204	33.3	120	95	30	12	14	9	64	42	43.7	17.1	M10	12.8	6.65	0.5
25	UELPE205	UEL205D1	PE205	36.5	130	105	30	12	14	10	70	42	44.4	17.5	M10	14.0	7.85	0.6
30	UELPE206	UEL206D1	PE206	42.9	155	121	36	17	20	11	82	54	48.4	18.3	M14	19.5	11.3	1.0
35	UELPE207	UEL207D1	PE207	47.6	161	127	38	17	20	12	92	54	51.1	18.8	M14	25.7	15.3	1.2
40	UELPE208	UEL208D1	PE208	49.2	171	137	40	17	20	12	98	52	56.3	21.4	M14	29.1	17.8	1.5
45	UELPE209	UEL209D1	PE209	54	180	146	40	17	20	13	105	60	56.3	21.4	M14	32.5	20.4	1.7
50	UELPE210	UEL210D1	PE210	57.2	195	159	45	19	22	14	114	65	62.7	24.6	M16	35.0	23.2	2.0
55	UELPE211	UEL211D1	PE211	63.5	207	171	45	19	22	15	125	65	71.4	27.8	M16	43.5	29.2	3.0
60	UELPE212	UEL212D1	PE212	69.8	220	184	55	19	22	17	137	70	77.8	31	M16	52.5	36.0	4.1

① If relubricatable type is needed, please order with suffix "D1". (Ex:UELPE204D1)

Flange unit

UELFE type

cylindrical bore with eccentric locking collar

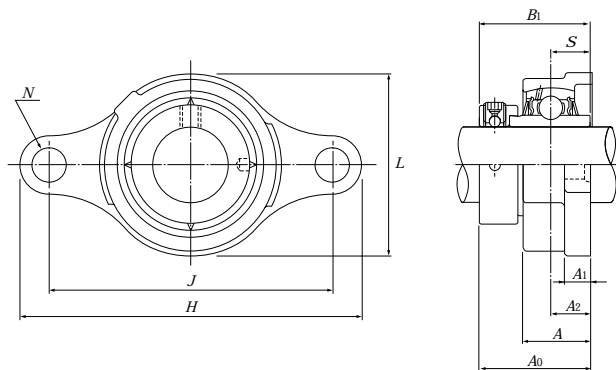
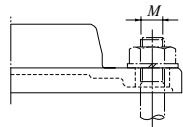

Shaft dia. mm	Unit number	Bearing number	Housing number	Nominal dimensions mm											Bolt size M	Basic load ratings		Mass of unit kg
				H	J	A2	A1	A	N	L	A0	B1	S	dynamic kN Cr		static kN Cor		
20	UELFE204	UEL204D1	FE204	112	90	15	10	25	12	57	41.6	43.7	17.1	M10	12.8	6.65	0.4	
25	UELFE205	UEL205D1	FE205	127	99	16	10	26	16	62	42.9	44.4	17.5	M14	14.0	7.85	0.5	
30	UELFE206	UEL206D1	FE206	145	117	18	10	30	16	73	48.1	48.4	18.3	M14	19.5	11.3	0.8	
35	UELFE207	UEL207D1	FE207	158	130	19	12	32	16	86	51.3	51.1	18.8	M14	25.7	15.3	1.1	
40	UELFE208	UEL208D1	FE208	172	144	21	12	35	16	95	55.9	56.3	21.4	M14	29.1	17.8	1.3	
45	UELFE209	UEL209D1	FE209	180	148	22	13	36	19	101	56.9	56.3	21.4	M16	32.5	20.4	1.6	
50	UELFE210	UEL210D1	FE210	189	157	22	13	37	19	106	60.1	62.7	24.6	M16	35.0	23.2	1.8	
55	UELFE211	UEL211D1	FE211	216	184	25	18	41	19	118	68.6	71.4	27.8	M16	43.5	29.2	2.7	
60	UELFE212	UEL212D1	FE212	241	202	29	18	46	23	129	74.8	77.8	31	M20	52.5	36.0	3.8	

① If relubricatable type is needed, please order with suffix "D1" (Ex:UELFE204D1)

Note: Please check NSK catalogue NO.E1154. for tolerances of inserts and housings.
Tolerance of insert bearings according to JIS B 1558.
Tolerance of housing according to JIS B 1559.
If inch size bore is needed, please contact NSK.

Pillow block unit

AELPE type

cylindrical bore with eccentric locking collar

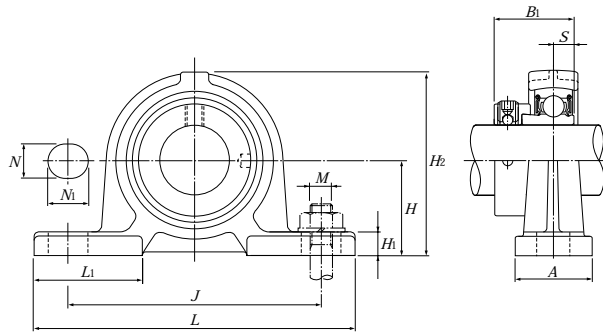

Shaft dia. mm	Unit number	Bearing number	Housing number	Nominal dimensions mm											Bolt size M	Basic load ratings		Mass of unit kg
				H	L	J	A	N	N _i	H _i	H ₂	L _i	B ₁	S		dynamic kN C _r	static kN C _{0r}	
20	AELPE204	AEL204	PE204	33.3	120	95	30	12	14	9	64	42	31	7.5	M10	12.8	6.65	0.5
25	AELPE205	AEL205	PE205	36.5	130	105	30	12	14	10	70	42	31	7.5	M10	14.0	7.85	0.5
30	AELPE206	AEL206	PE206	42.9	155	121	36	17	20	11	82	54	35.7	9	M14	19.5	11.3	0.9
35	AELPE207	AEL207	PE207	47.6	161	127	38	17	20	12	92	54	38.9	9.5	M14	25.7	15.3	1.1
40	AELPE208	AEL208	PE208	49.2	171	137	40	17	20	12	98	52	43.7	11	M14	29.1	17.8	1.4
45	AELPE209	AEL209	PE209	54	180	146	40	17	20	13	105	60	43.7	11	M14	32.5	20.4	1.5
50	AELPE210	AEL210	PE210	57.2	195	159	45	19	22	14	114	65	43.7	11	M16	35.0	23.2	1.8

① If relubricatable type is needed, please order with suffix "D1". (Ex:AELPE204D1)

Flange unit

AELFE type

Cylindrical bore with eccentric locking collar

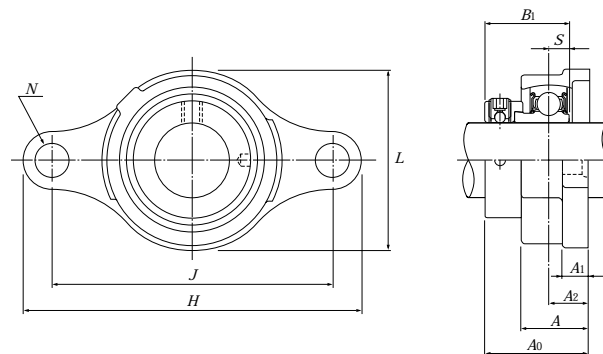
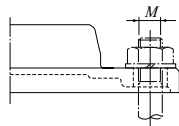

Shaft dia. mm	Unit number	Bearing number	Housing number	Nominal dimensions mm											Bolt size M	Basic load ratings		Mass of unit kg
				H	J	A ₂	A ₁	A	N	L	A ₀	B ₁	S	dynamic kN C _r		static kN C _{0r}		
20	AELFE204	AEL204	FE204	112	90	15	10	25	12	57	38.5	31	7.5	M10	12.8	6.65	0.4	
25	AELFE205	AEL205	FE205	127	99	16	10	26	16	62	39.5	31	7.5	M14	14.0	7.85	0.4	
30	AELFE206	AEL206	FE206	145	117	18	10	30	16	73	44.7	35.7	9	M14	19.5	11.3	0.7	
35	AELFE207	AEL207	FE207	158	130	19	12	32	16	86	48.4	38.9	9.5	M14	25.7	15.3	1.0	
40	AELFE208	AEL208	FE208	172	144	21	12	35	16	95	53.7	43.7	11	M14	29.1	17.8	1.2	
45	AELFE209	AEL209	FE209	180	148	22	13	36	19	101	54.7	43.7	11	M16	32.5	20.4	1.4	
50	AELFE210	AEL210	FE210	189	157	22	13	37	19	106	54.7	43.7	11	M16	35.0	23.2	1.6	

① If relubricatable type is needed, please order with suffix "D1" (Ex:AELFE204D1)

Note: Please check NSK catalogue NO.E1154. for tolerances of inserts and housings.
Tolerance of insert bearings according to JIS B 1558.
Tolerance of housing according to JIS B 1559.
If inch size bore is needed, please contact NSK.

Pillow block unit

ASPE type

Cylindrical bore with set screw

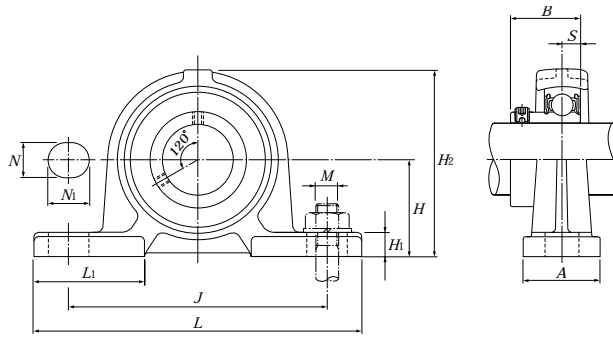

Shaft dia. mm	Unit number	Bearing number	Housing number	Nominal dimensions mm											Bolt size M	Basic load ratings		Mass of unit kg
				H	L	J	A	N	N _i	H ₁	H ₂	L ₁	B	S		dynamic kN C _r	static kN C _{0r}	
20	ASPE204	AS204	PE204	33.3	120	95	30	12	14	9	64	42	25	7	M10	12.8	6.65	0.4
25	ASPE205	AS205	PE205	36.5	130	105	30	12	14	10	70	42	27	7.5	M10	14.0	7.85	0.5
30	ASPE206	AS206	PE206	42.9	155	121	36	17	20	11	82	54	29	8	M14	19.5	11.3	0.8
35	ASPE207	AS207	PE207	47.6	161	127	38	17	20	12	92	54	34	8.5	M14	25.7	15.3	1.0
40	ASPE208	AS208	PE208	49.2	171	137	40	17	20	12	98	52	38	9	M14	29.1	17.8	1.2
45	ASPE209	AS209	PE209	54	180	146	40	17	20	13	105	60	40	9.5	M14	32.5	20.4	1.4
50	ASPE210	AS210	PE210	57.2	195	159	45	19	22	14	114	65	42	10	M16	35.0	23.2	1.7

① If relubricatable type is needed, please order with suffix "D1". (Ex:ASPE204D1)

Flange unit

ASFE type

Cylindrical bore with set screw

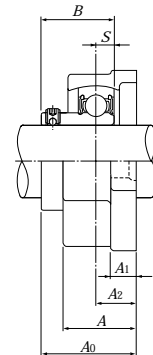
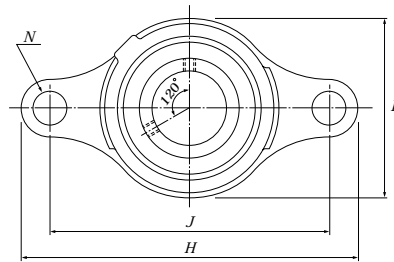
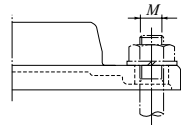

Shaft dia. mm	Unit number	Bearing number	Housing number	Nominal dimensions mm										Bolt size M	Basic load ratings		Mass of unit kg
				H	J	A ₂	A ₁	A	N	L	A ₀	B	S		dynamic kN C _r	static kN C _{0r}	
20	ASFE204	AS204	FE204	112	90	15	10	25	12	57	33	25	7	M10	12.8	6.65	0.3
25	ASFE205	AS205	FE205	127	99	16	10	26	16	62	35.5	27	7.5	M14	14.0	7.85	0.4
30	ASFE206	AS206	FE206	145	117	18	10	30	16	73	39	29	8	M14	19.5	11.3	0.6
35	ASFE207	AS207	FE207	158	130	19	12	32	16	86	44.5	34	8.5	M14	25.7	15.3	0.8
40	ASFE208	AS208	FE208	172	144	21	12	35	16	95	50	38	9	M14	29.1	17.8	1.1
45	ASFE209	AS209	FE209	180	148	22	13	36	19	101	52.5	40	9.5	M16	32.5	20.4	1.3
50	ASFE210	AS210	FE210	189	157	22	13	37	19	106	54	42	10	M16	35.0	23.2	1.5

① If relubricatable type is needed, please order with suffix "D1" (Ex:ASFE204D1)

Note: Please check NSK catalogue NO.E1154. for tolerances of inserts and housings.
Tolerance of insert bearings according to JIS B 1558.
Tolerance of housing according to JIS B 1559.
If inch size bore is needed, please contact NSK.

Pillow block unit

CSPE type

Cylindrical bore

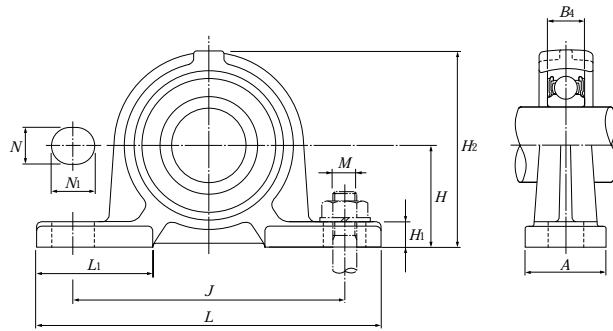

Shaft dia. mm	Unit number	Bearing number	Housing number	Nominal dimensions mm										Bolt size M	Basic load ratings		Mass of unit kg
				H	L	J	A	N	Ni	Hi	H2	L1	B1		dynamic kN Cr	static kN Cor	
20	CSPE204LLU	CS204LLU	PE204	33.3	120	95	30	12	14	9	64	42	14	M10	12.8	6.65	0.4
25	CSPE205LLU	CS205LLU	PE205	36.5	130	105	30	12	14	10	70	42	15	M10	14.0	7.85	0.4
30	CSPE206LLU	CS206LLU	PE206	42.9	155	121	36	17	20	11	82	54	16	M14	19.5	11.3	0.7
35	CSPE207LLU	CS207LLU	PE207	47.6	161	127	38	17	20	12	92	54	17	M14	25.7	15.3	0.9
40	CSPE208LLU	CS208LLU	PE208	49.2	171	137	40	17	20	12	98	52	18	M14	29.1	17.8	1.1
45	CSPE209LLU	CS209LLU	PE209	54	180	146	40	17	20	13	105	60	19	M14	32.5	20.4	1.2
50	CSPE210LLU	CS210LLU	PE210	57.2	195	159	45	19	22	14	114	65	20	M16	35.0	23.2	1.5

Flange unit

CSFE type

Cylindrical bore

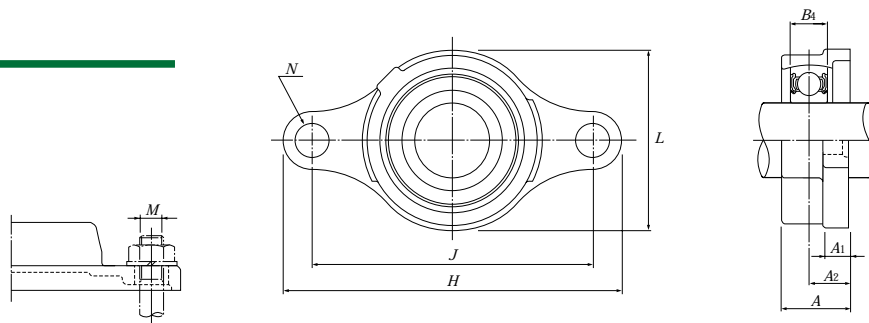

Shaft dia. mm	Unit number	Bearing number	Housing number	Nominal dimensions mm										Bolt size M	Basic load ratings		Mass of unit kg
				H	J	A2	A1	A	N	L	B1	dynamic kN Cr	static kN Cor				
20	CSFE204LLU	CS204LLU	FE204	112	90	15	10	25	12	57	14	M10	12.8	6.65	0.3		
25	CSFE205LLU	CS205LLU	FE205	127	99	16	10	26	16	62	15	M14	14.0	7.85	0.4		
30	CSFE206LLU	CS206LLU	FE206	145	117	18	10	30	16	73	16	M14	19.5	11.3	0.5		
35	CSFE207LLU	CS207LLU	FE207	158	130	19	12	32	16	86	17	M14	25.7	15.3	0.8		
40	CSFE208LLU	CS208LLU	FE208	172	144	21	12	35	16	95	18	M14	29.1	17.8	0.9		
45	CSFE209LLU	CS209LLU	FE209	180	148	22	13	36	19	101	19	M16	32.5	20.4	1.1		
50	CSFE210LLU	CS210LLU	FE210	189	157	22	13	37	19	106	20	M16	35.0	23.2	1.3		

Housing tolerances according to JIS B 1559.